

4

3

2

1

NOTES: UNLESS OTHERWISE SPECIFIED

- 1 INTERPRET DRAWING IN ACCORDANCE WITH ASME Y14.5-1994.
- 2 PARTS SUPPLIED IN REEL FORM AND CUT TO LENGTH. 25,000 PINS (12,500 DUAL ROW POSITIONS) PER AUTOHEADER™ REEL. FEEDER COMPATIBLE SPLICES PERMITTED. 2 SPLICES MAX/REEL.
- 3 FEEDER CUTOFF FROM CONTINUOUS STRIP.
- 4 DIMENSIONS INDICATED ARE TO BE MEASURED WITH INSULATOR RESTRAINED FLAT ON DATUMS D & F.
- 5 HEADERS CAN BE SUPPLIED CUT TO LENGTH AS INDICATED.
- 6 PERPENDICULARITY TOLERANCE IS A PER SIDE VALUE.

PART NO./ORDERING CODE

23-1038 D 00 □ □ X

TYPE
2 ROW .100 [2.54]
CENTERS

PIN SHAPE/SIZE
.025[0.64] SQ.

TOTAL NO. OF POS.
00= CONTINUOUS REEL
5 CUT HEADER SIZES:
2 TO 26 POSITIONS
BULK PACKAGED IN POLYBAG

VARIATION
OMIT FOR STD

FINISH:
AA = 120µ" [3.05 MICRONS] MIN. 90/10 SnPb
OVER 50µ" [1.27 MICRONS] MIN. Ni.
TT = 160µ" [4.06 MICRONS] MIN. Sn (Pb FREE)
OVER 80µ" [2.03 MICRONS] MIN. Ni.

REV	REVISION RECORD	ECN	BY	APVD	DATE
A	INIT RELEASE	502055	Pete	PVB	03/25/02
B	ADDED A2 LENGTH PER EWR 104733	503504	BILL	PVB	09/12/05
C	REVISE TOLERANCE CDR 301942	504882	HR	PVB	2/28/07
D	REMOVE COIN PER EWR 105540	505147	HR	PVB	03/16/07
E	ADDED A3 LENGTH PER EWR106486	505842	Pete	PVB	09/09/09

DIMENSIONS:

CODE	A	B	C	REF
A1	.504 [12.80]	.09 [2.3]	.694 [17.63]	
A2	.455 [11.56]	.09 [2.3]	.646 [16.40]	
A3	.525 [13.33]	.09 [2.3]	.715 [18.16]	

CUSTOM DIMENSIONS ARE AVAILABLE UPON REQUEST TO FACTORY

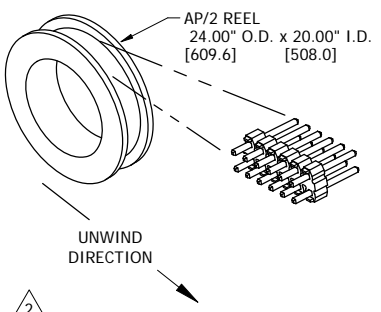
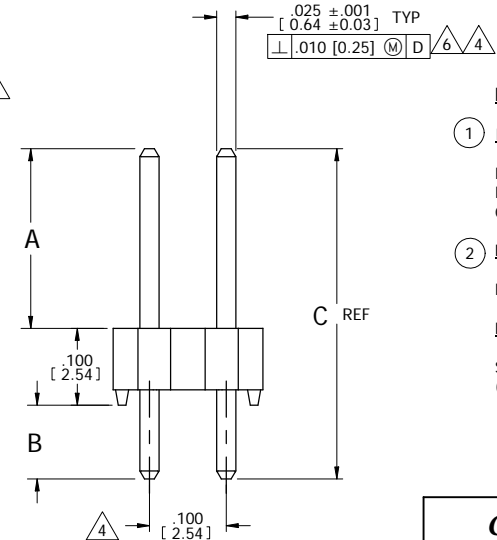
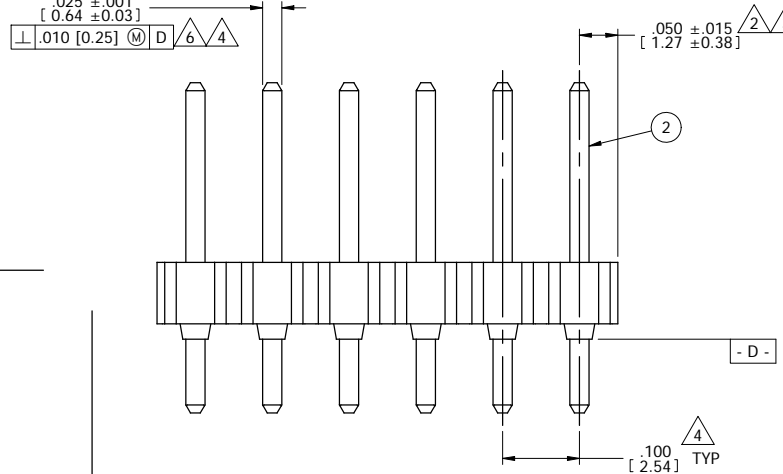
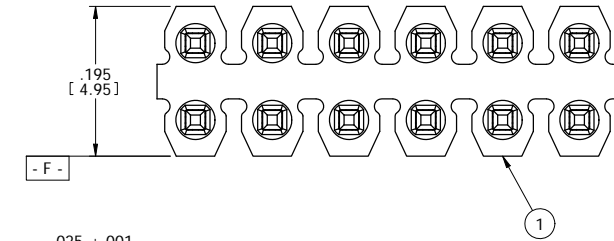
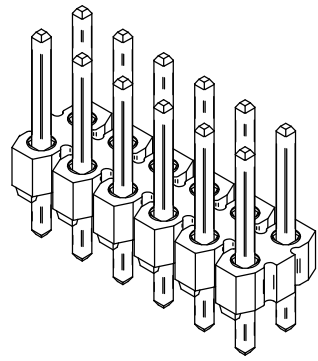

REELED HEADER ORIENTATION

MATERIAL:

- 1 INSULATOR:
HIGH TEMPERATURE THERMOPLASTIC,
FLAMMABILITY RATED: UL 94V-0
COLOR: BLACK
 - 2 PIN:
BRASS C26000
- FINISH:
SEE PART NO. / ORDERING CODE
(PIN TIPS BARE AT CUTOFF)

CONFIDENTIAL CUSTOMER DRAWING

TOLERANCES UNLESS OTHERWISE SPECIFIED DIMENSIONS IN INCHES (mm)		Autosplice, Inc. 10121 Barnes Canyon Rd. San Diego, CA 92121-2725. 858.535.0077	
DECIMAL: .XX = ± .01 (X.X) = ± [0.25] XXX = ± .005 (X.XX) = ± [0.13]	ANGULAR: ± 5°	DATE: 5-29-01	DATE: 5-29-01
		ENGINEERED BY: Pete	DATE: 5-29-01
		DESIGNED BY: PVB	DATE: 5-29-01
TITLE: AUTOHEADER™, 2 ROWS, .100 [2.54] CTRS			
SIZE: C	FORM NO: OAE89	ORDER NUMBER: C23-1038	REVISION: E
SCALE: 8:1 (P/N: C23-1038) (REV: 20) (MODEL: NO 23-1038) (REV: 20) (PAGE: 1 OF 1)			

The drawing and the information set forth hereon are the property of Autosplice, Inc. and are to be held in trust and confidence. Publication, disclosure, or use for any purpose not expressly authorizing in writing by Autosplice, Inc. is prohibited.

4

3

2

1