

NOTES: UNLESS OTHERWISE SPECIFIED

1. INTERPRET DRAWING IN ACCORDANCE WITH ASME Y14.5-1994.

2. PART SUPPLIED ON A CONTINUOUS REEL AS SHOWN, 25,000 ±15% PINS PER REEL. FEEDER COMPATIBLE SPLICES PERMITTED, 2 SPLICES MAX PER REEL.

3. COMPLIANT TIPS ARE BARE AT CUT-OFF.

4. .010 [0.25] MAX RADII AND FILLET.

5. ASSEMBLY DIMENSIONS ARE MEASURED IN A RESTRAINED STATE.

6. HEADER SIZES CUT FROM A REEL ARE PACKAGED IN BULK.

7. CONSULT AUTOSPlice FOR INSERTION TOOLING.

8. RECOMMENDED .062" THICK PC BOARD HOLE:
 DRILLED HOLE - Ø .0453±.0010 [Ø 1.151±0.025]
 COPPER PLATED - Ø .0410±.0020 [Ø 1.041±0.051]
 (HASL) TIN/LEAD PLATED - Ø .040±.003 [1.02±0.08]

DRILLED HOLE - Ø .0453±.0010 [Ø 1.151±0.025]
 COPPER PLATED - Ø .0410±.0020 [Ø 1.041±0.051]
 NICKEL PLATED - Ø .040±.002 [1.02±0.08]
 GOLD PLATED - Ø .040±.002 [1.02±0.05]

DRILLED HOLE - Ø .0453±.0010 [Ø 1.151±0.025]
 COPPER PLATED - Ø .0413±.0020 [Ø 1.041±0.051]
 SILVER PLATED - Ø .040±.002 [1.02±0.05]

REV	REVISION RECORD	ECN	BY	APVD	DATE
X9	PER CDR 300654	-	JB	JB	11/08/02
A	NEW RELEASE PER EWR 102132	502669	JB	JB	04/02/03
B	REVISED PER EWR 104801	504295	BILL	PVB	01/06/06
C	ADD PLATING PER EWR 105547	505080	HR	PVB	8/17/2007
D	ADD INSULATOR COLOR PER EWR 105685	505173	HR	PVB	11/9/2007
E	UPDATE P/N PER EWR105973	505481	HR	PVB	7/30/2008

PART NO. / ORDERING CODE

TYPE: 2 ROW .100 [2.54] CENTERS

VARIATION: 1 = COLOR NATURAL

FINISH:
 AA- .000040-.000120 [0.00102-0.00305]
 TIN/LEAD (90/10) OVER .000050 [0.00127]
 MIN NICKEL
 TT- .000040-.000080 [0.00102-0.00203] TIN (LEAD FREE) OVER .000080 [0.00203] MIN NICKEL

DIMENSIONS

CODE	Z
A1	.419 [10.65]
A2	.437 [11.10]
A3	.531 [13.50]

RECT. PIN COMPLIANT
 .025 X .0394
 [0.64] [1.00]

TOTAL NO. OF POS.
 2 00 = CONTINUOUS REEL

CUT HEADER SIZES:
 2 TO 40 POSITIONS BULK PACKAGED IN THERMOFORMED TRAY

ADDITIONAL PIN SIZES & LENGTHS UP TO "Z"=1.575 [40.00] CAN BE MADE UPON REQUEST

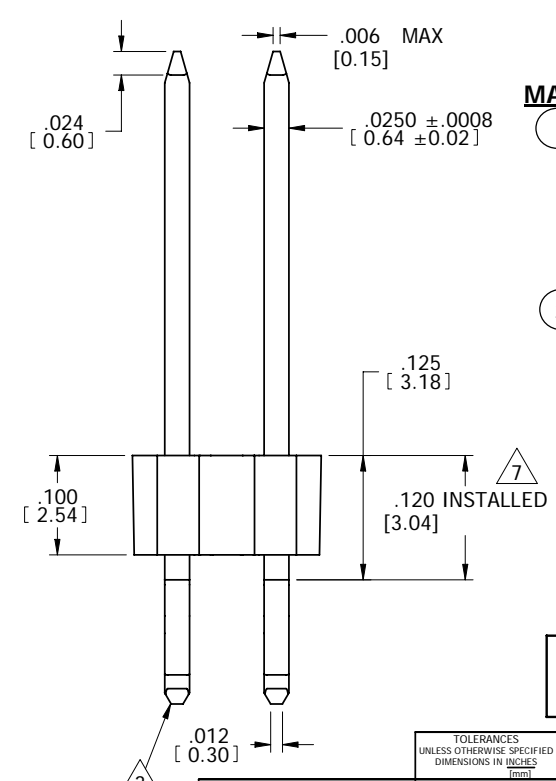
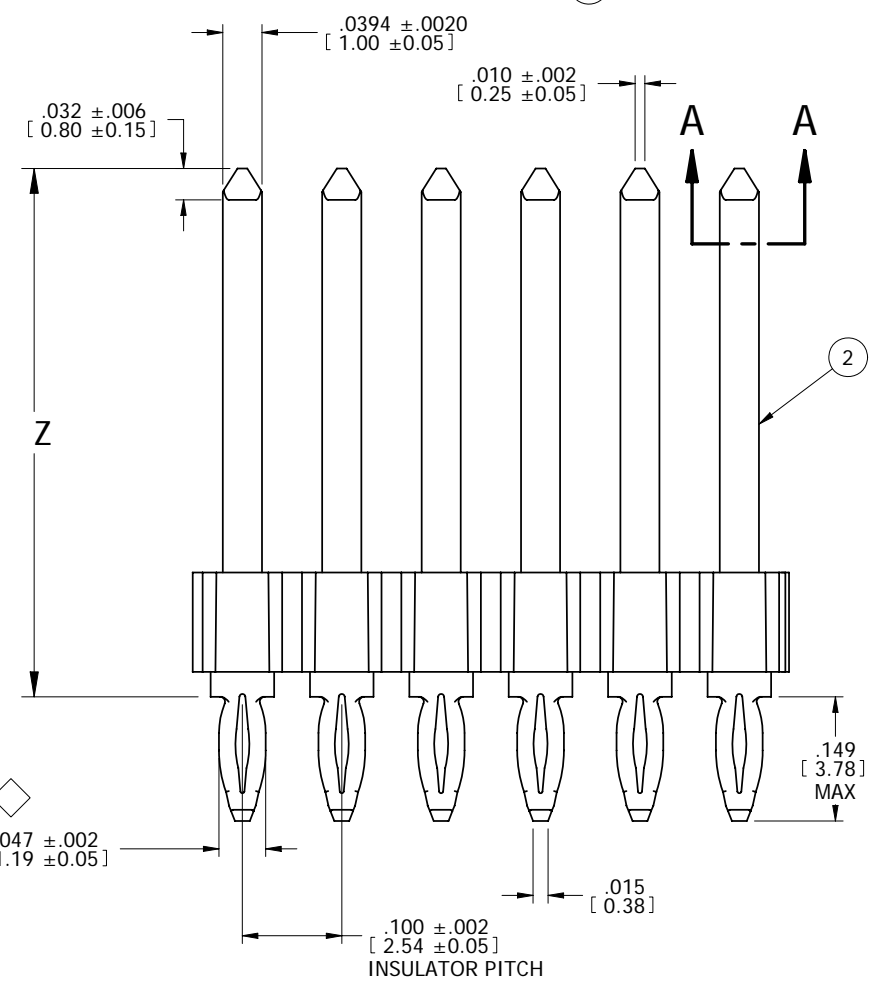
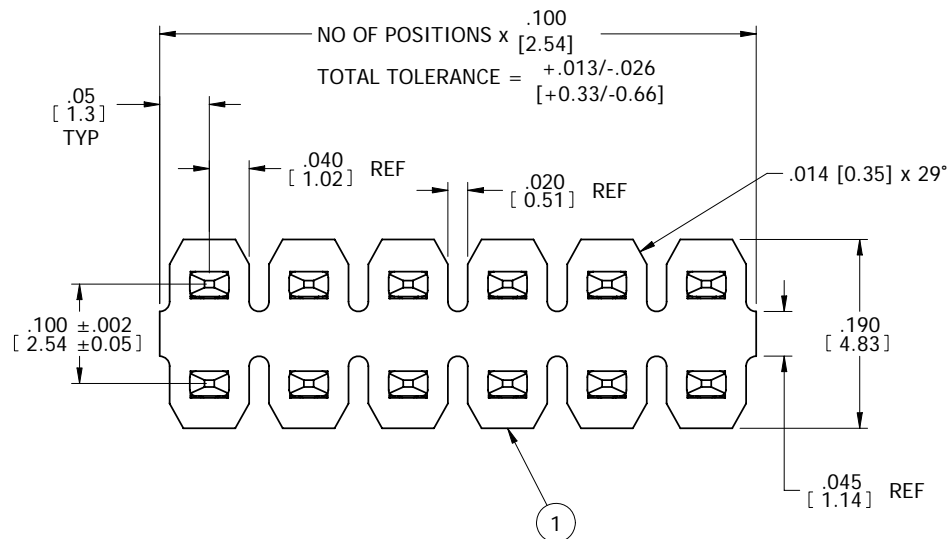

MATERIAL:

1 **INSULATOR:**
 GLASS FILLED THERMOPLASTIC POLYESTER
 FLAMMABILITY RATED: UL 94HB
 COLOR: FINISH "AA" & "TT" = BLACK
 FINISH "TT1" = NATURAL

2 **PIN:**
 COPPER ALLOY

FINISH:
 SEE PART NO. / ORDERING CODE

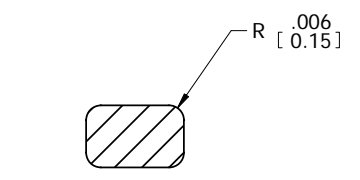

SECTION A-A
 SCALE: 20:1

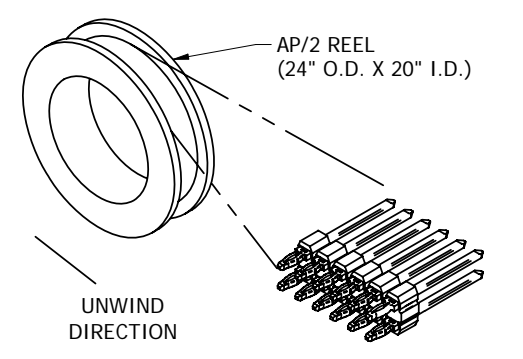

CUSTOMER DRAWING

TOLERANCES UNLESS OTHERWISE SPECIFIED DIMENSIONS IN INCHES (mm)		Autosplice, Inc. 10121 Barnes Canyon Rd. San Diego, CA 92121-2725 858-535-0077	
DECIMAL	XX = ±.01 [X.X] ±[0.3]	DATE	5-17-02
	XXX = ±.004 [X.XX] ±[0.10]	ENGINEERED BY	Pete
ANGULAR	± 5°	DATE	5-17-02
THIRD ANGLE PROJECTION		DRAWN BY	
TITLE		PVB	
AUTOHEADER™, 2 ROWS, .100 [2.54] CTRS			
SIZE	C	DRAWING NUMBER	C23-1042
SCALE	8:1	MODEL NO.	23-1042.asm

The drawing and the information set forth hereon are the property of Autosplice, Inc. and are to be held in trust and confidence. Publication, disclosure, or use for any purpose not expressly authorizing in writing by Autosplice, Inc. is prohibited.