

4

3

2



1

NOTES: UNLESS OTHERWISE SPECIFIED

- 1. INTERPRET DRAWING IN ACCORDANCE ASME Y14.5-1994.
- 2. PART SUPPLIED AS CUT HEADERS IN PACKAGING TUBES AS SHOWN, SEALED WITH PLASTIC TAPE. SEE TABLE FOR QTY PER TUBE.
- 3. DIMENSIONS INDICATED ARE TO BE MEASURED WITH INSULATORS RESTRAINED FLAT.
- 4. PART MARKED WITH A PERMANENT WHITE INK STRIPE LOCATED ON EITHER SIDE AS SHOWN.

AUTOSPLICE PART NO.	TOTAL NO. OF PINS	PART MARKING	QTY PER TUBE
23-1070-26AA	26	-	18
23-1070-26TT1		STRIPE 	
23-1070-14AA	14	-	33

PART NO./ORDERING CODE

23-1070 -   X

TYPE
2 ROW .100 [2.54] CENTERS, STACKING

VARIATION
OMIT FOR STD
1= WHITE STRIPE

FINISH:
AA= 120μ" [3.05 MICRONS] MIN. 90/10 SnPb
OVER 50μ" [1.27 MICRONS] MIN. Ni.
TT= 160μ" [4.06 MICRONS] MIN. MATTE Sn (Pb FREE) OVER 80μ" [2.03 MICRONS] MIN. Ni.



TOTAL NO. OF POS.
CUT HEADER SIZES:
SEE TABLE

 BULK PACKAGED IN TUBES

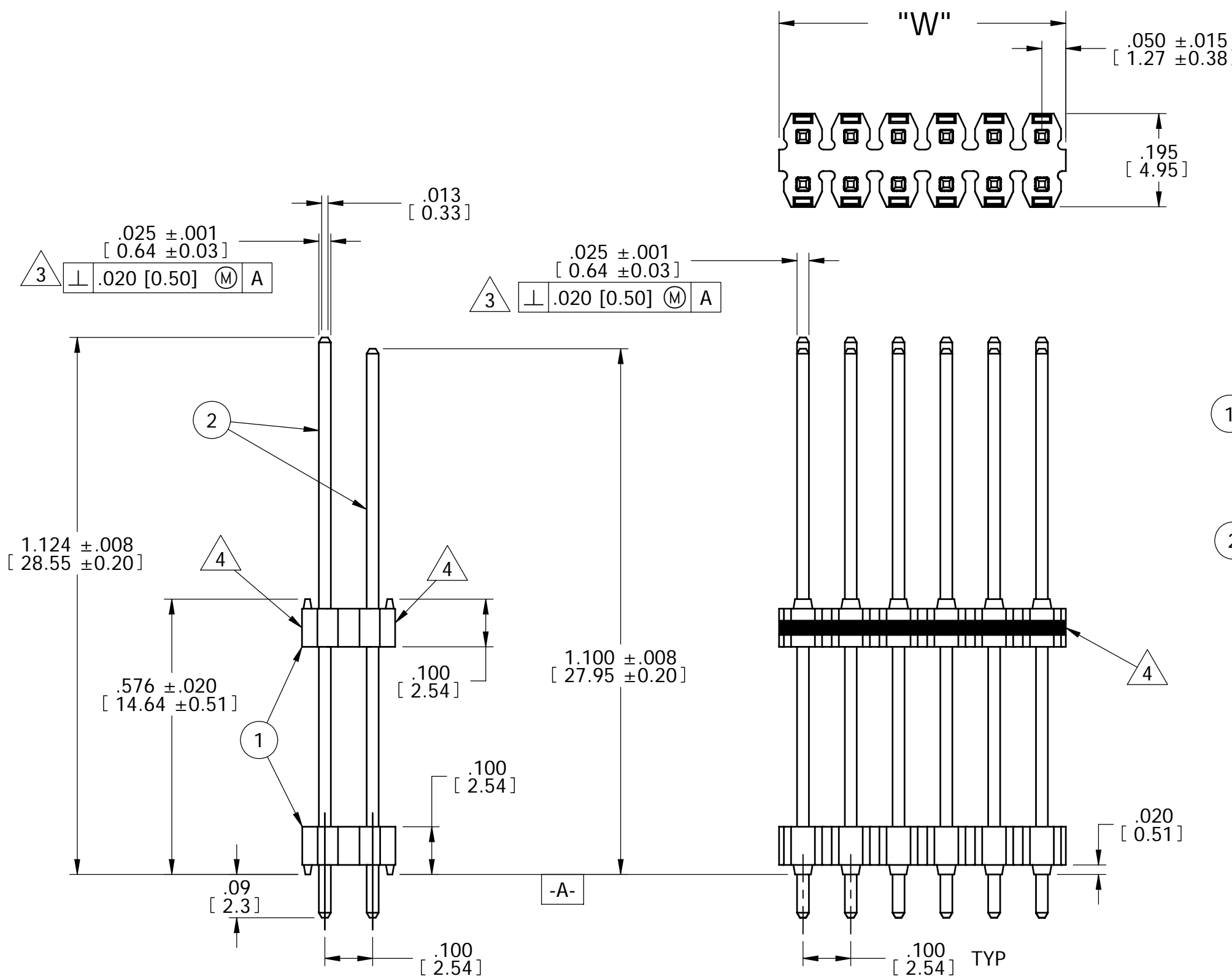
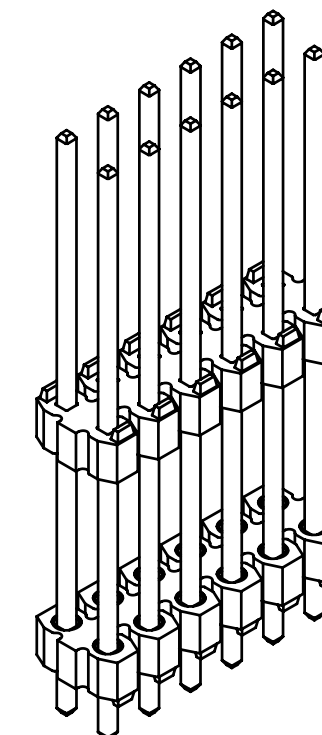
REV	REVISION RECORD	ECN	BY	APVD	DATE
A	INITIAL RELEASE	505147	HR	PVB	08/20/07
B	REVISE PKGNG QTY PER EWR105824	505297	HR	PVB	02/25/08
C	ADDED P/N 23-1070-26TT1 PER EWR106486	505842	Pete	PVB	08/24/09
D	REPL. -26TT WITH -26TT1 PER CDR302550	505879	Pete	PVB	10/13/09



MATERIAL:

-  **INSULATOR:**
HIGH TEMPERATURE THERMOPLASTIC, FLAMMABILITY RATED: UL 94V-0, COLOR: BLACK
 -  **PIN:**
BRASS, C26000
- FINISH:** (BARE TIPS PERMISSIBLE)
- AA= 120μ" [3.05 MICRONS] MIN. 90/10 SnPb OVER 50μ" [1.27 MICRONS] MIN. Ni.
- TT= 160μ" [4.06 MICRONS] MIN. MATTE Sn (Pb FREE) OVER 80μ" [2.03 MICRONS] MIN. Ni.



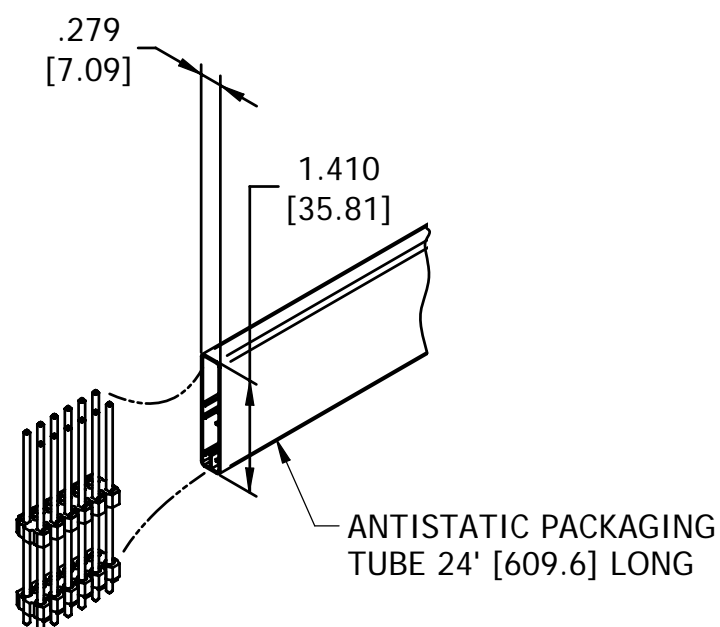









 **PACKAGED HEADER ORIENTATION**



P/N 23-1070-12 SHOWN

CONFIDENTIAL CUSTOMER DRAWING

The drawing and the information set forth herein are the property of AutosplICE, Inc. and are to be held in trust and confidence. Publication, disclosure, or use for any purpose not expressly authorizing in writing by AutosplICE, Inc. is prohibited.

TOLERANCES UNLESS OTHERWISE SPECIFIED DIMENSIONS IN INCHES (mm)		autosplICE [®]		AutosplICE, Inc. 10121 Barnes Canyon Rd. San Diego, CA 92121-2725 858-535-0077	
DECIMAL: .XX = ± .01 [X.X] = ± [0.25] XXX = ± .005 [X.XX] = ± [0.13]	THIRD ANGLE PROJECTION	DRAWN BY: HR	DATE: 8-20-07	ENGINEERED BY: H REYNOLDS	DATE: 8-20-07
ANGULAR: ± 5°	TITLE: AUTOHEADER™, DUAL INSULATOR, .025 [0.64] SQ PIN STAGGERED	SIZE: C	FSCM NO: OAE89	DRAWING NUMBER: C23-1070-    	REVISION: D
 DENOTES SPECIAL CHARACTERISTIC	SCALE: 4:1	CAD NO: C23-1070-    	MODEL NO: 23-1070-    	SHEET 1 OF 1	